

The purpose of the **PETKUS Trough Chain Conveyor TK 200 / TK 300** is the horizontal transport of free flowing, bulky products such as grain, pulses, oilseeds and similar agricultural products.

Advantages:

- Positioning of the inlets and outlets freely configurable
- Modular design through duct lengths of 500 mm, 1000 mm, 2000 mm and 3000 mm
- Large conveying distances of up to 70 m
- Quiet, low-wear operation due to plastic guiding rails

Description:

The transport of the product is usually performed from the tensioning station to the drive station.

The product is transported into the Trough Chain Conveyor over the inlet. A conveyor chain with paddles moves the material along the circular bottom of the conveyor trough to the outlet.

The conveyor chain is driven by a sprocket by the drive station. The conveying belt is tensioned on the opposite side by the tensioning station.

Construction:

The Trough Chain Conveyor is equipped with conveyor troughs, a conveyor chain, inlets and outlets as well as the drive and the tensioning station. The drive is operated with a gear motor.

Standard Equipment:

- Screwed conveyor troughs with a roof of galvanized sheet steel
- Drive station with electric motor
- Tensioning Station
- Inlet
- Model for the unidirectional transport of products

Options:

- Manual, pneumatic or motorized intermediate outlets
- Outlet hopper for the tensioning station
- Model for the reversible transport of products
- Model for the double-sided transport of products
- Device for transporting the product back

Trough Chain Conveyor Type TK 200 / TK 300

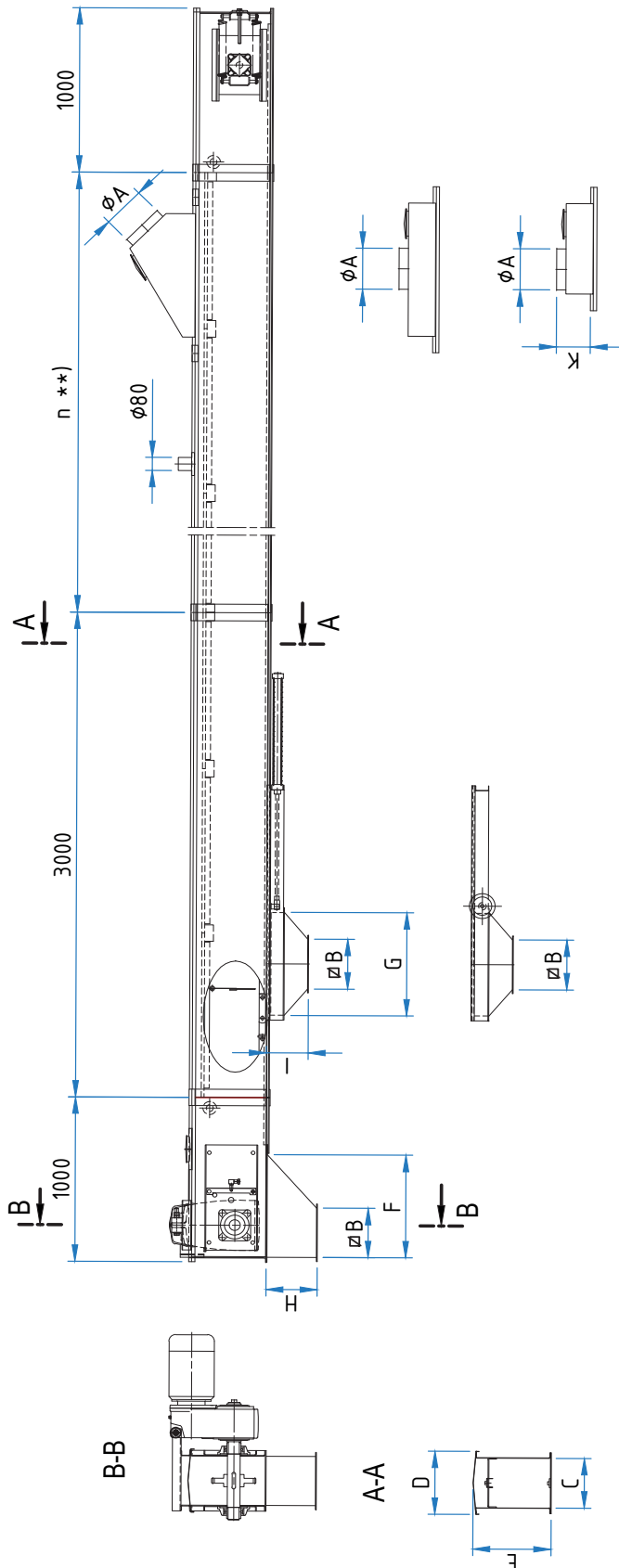

Technical alteration reserved.